

Lipase-Catalyzed Glycerolysis of Soybean Oil in Supercritical Carbon Dioxide

Michael A. Jackson, and Jerry W. King*

Food Quality and Safety Research, NCAUR, ARS, USDA, Peoria, IL 61604

ABSTRACT: The transesterification of soybean oil with glycerol, 1,2-propanediol, and methanol by an immobilized lipase in flowing supercritical carbon dioxide for the synthesis of monoglycerides is described. A lipase from *Candida antarctica* was used to catalyze the reaction of soybean oil with glycerol, 1,2-propanediol, ethylene glycol, and methanol. Reactions were performed in supercritical carbon dioxide at a density of 0.72 g/L and at a flow rate of 6 $\mu\text{L}/\text{min}$ (expanded gas). The substrates were added at flows ranging from 2.5 to 100 $\mu\text{L}/\text{min}$. Monoglycerides were obtained at up to 87 wt%, and fatty acid methyl esters at nearly 100 wt%. The reactivity of the alcohols paralleled the solubility of the substrate in liquid carbon dioxide. Glycerol has the slowest reaction rate, only 2% of that of methanol.

JAOCS 74, 103–106 (1997).

KEY WORDS: Lipase, monoglycerides, supercritical carbon dioxide, transesterification.

The use of monoglycerides in pharmaceutical formulations and prepared foods continues to increase. In pharmaceuticals, monoglycerides are used as binders in tablets and as emollients for transdermal, slow-release drugs. In the food industry, they serve to stabilize emulsions in sauces and baked goods. The manufacture of monoglycerides is an energy-intensive process that involves heating (240°C) of a stirred emulsion of vegetable oil and glycerol in the presence of an inorganic catalyst. At the end of the reaction, the mixture is rapidly cooled to prevent the reverse reaction from decreasing the yield. The yield of monoglycerides is usually around 40%, and the crude product is colored due to thermal degradation products. This mixture of free fatty acids, mono-, di-, and triglycerides is then distilled to give a food-grade material that is 90% monoglycerides. Glycerolysis technology and many of the patented processes have been reviewed by Sonntag (1).

There are now several reports on the use of lipases to catalyze the glycerolysis of fats and oils. Enzymatic syntheses have the advantage of catalysis at lower temperatures, which prevents the discoloration and alteration of unsaturated fatty acids that is common at elevated temperatures. Yamane *et al.* surveyed 13 kinds of microbial lipases for their ability to catalyze glycerolysis to corn oil in neat batch reactions (2) and

also studied the continuous glycerolysis of olive oil by *Pseudomonas fluorescens* in a membrane bioreactor (3). The influence of water activity on this reaction has also been studied (4). The authors found that, in their reactor, the yield of monoglycerides increased with decreasing water activity and that the highest monoglyceride yield (70%) was attained at the lowest water activity (0.23). Tallow has been converted to monoglycerides at a 50% yield by immobilized *Mucor meihei* lipase (5), at a 70% yield by lipase from *P. fluorescens* (6) and at a 90% yield by a lipase from *Pseudomonas* sp. (7,8). Lipase G from *Penicillium* sp. has been used in hexane to catalyze the synthesis of monoglycerides from glycerol and fatty acids and fatty acid esters (9); a 1,3-specific lipase from *Rhizopus delemar* has been used in a microemulsion to prepare monoglycerides by selective removal of the fatty acids from the 1,3-positions of the triglyceride (10,11). Regioisomerically pure 1(3)-*rac*-monoglycerides have also been prepared by using several lipases and substrate combinations (12).

The use of supercritical carbon dioxide as a solvent and reaction medium for lipids has grown rapidly in recent years (13,14). Supercritical carbon dioxide has several advantages over organic solvents (15): The solvent properties of supercritical carbon dioxide can be readily modified by adjusting pressure or temperature; the diffusivity of solutes in carbon dioxide is higher than in organic solvents. Carbon dioxide can easily be removed from the reaction products to minimize the need for costly downstream cleanup. When carbon dioxide is used in lieu of organic solvents, it has the additional benefit of being an environmentally benign process.

In a previous study, we showed that an immobilized lipase from *Candida antarctica* catalyzed the formation of fatty acid methyl esters from seed oils and methanol in flowing supercritical carbon dioxide (11). We also noted that glycerol formed as a result of the methanolysis and flowed out of the system with the products upon decompression. This suggested that glycerol could be a good reagent in supercritical carbon dioxide, despite its low solubility in carbon dioxide (16). In this paper, we report on the efficient reaction of glycerol, 1,2-propanediol, and ethylene glycol with soybean oil in flowing supercritical carbon dioxide.

MATERIALS AND METHODS

Corn, soybean, and olive oils were from a local grocer. Cottonseed oil was from P.V.O. Foods (Jacksonville, IL). Glyc-

*To whom correspondence should be addressed at Food Quality and Safety Research, NCAUR, ARS, USDA, 1815 N. University Ave., Peoria, IL 61604.

erol and 1,2-propanediol were from Fisher Chemical (Fair Lawn, NJ). Ethylene glycol was from J.T. Baker (Phillipsburg, NJ). These reagents were used without further purification. Novozym 435 (*C. antarctica*) was purchased from Novo Nordisk (Danbury, CT). The immobilized enzyme is described by the manufacturer as having 7000 units/g toward propyl laurate. Karl-Fischer titrations were used to determine water content of the reagents and of the catalyst. The titrant was purchased from Aldrich Chemical (Milwaukee, WI).

A rapid screen for reactivity of the enzyme and each substrate was performed with an Isco SFX 2-10 extractor (Isco Inc., Lincoln, NE). Components of the reaction (1 g Novozym 435, \approx 50 mg oil and alcohol) were placed inside a 10-mL extraction cell, heated and pressurized to reaction conditions; after a period of 15–60 min, the products were swept from the cell into a receiver. The system used for the experiments with flowing CO₂ was a modified version of the apparatus previously described (17). Owing to the low solubility of monoglycerides in supercritical carbon dioxide, the micrometering valve and the receiver were placed inside the oven so that the entire system was maintained at the reaction temperature (Fig. 1). For the reactions, Novozym 435 (10 g) was placed in a stainless steel vessel (0.8 × 10.2 cm), which had its end plugged with glass wool. Reagents were pumped into the carbon dioxide stream by separate syringe pumps (100DX pumps, Isco, Inc.). Substrate volume ratios were chosen to give the highest conversion of soybean oil and were as follows (expressed as μ L alcohol/ μ L soybean oil): glycerol, 0.5; 1,2-propanediol and ethylene glycol, 0.75; methanol, 1.2. Carbon dioxide flow rates were controlled by a micrometering valve and measured with a dry test meter. Products were collected after depressurization

into a 100-mL round-bottomed flask. Supercritical fluid chromatographic (SFC) analyses were performed as previously described (11). Identification of transesterification products was previously determined by SFC retention times of standards and by retention times on reversed-phase high-pressure liquid chromatography (18).

RESULTS

Screening for activity. Small-scale reactions were carried out in an Isco SFX 2-10 extraction module to screen reaction conditions rapidly. Corn, cottonseed, olive, and soybean oils all were found to undergo the glycerolysis reaction in a similar manner. Conditions were optimized for soybean oil. The reaction occurred at temperatures of 40–70°C and pressures of 20.7–34.5 MPa. A pressure and temperature of 27.6 MPa and 70°C, respectively, were found to be optimal.

Effect of water on transesterification. Karl-Fischer titrations were used to measure the initial water content of the Novozym 435, which was found to be 1.4 wt%; separate glycerol supplies were 0.7 and 4.2 wt%; 1,2-propanediol was 2.1 wt%; methanol, 0.01 wt%; ethylene glycol, 0.8 wt%; and soybean oil, <0.1%. The glycerolysis reaction depended on the water content of the reagents. Glycerolysis with glycerol of 4.2 wt% water content had only 60% of the activity of glycerol with 0.7 wt% water (Table 1). We also observed an extensive lag time (\approx 3 h) at the start of the reaction before yields reached their ultimate levels. A sample of Novozym 435 that had been exposed to supercritical carbon dioxide and had converted several grams of soybean oil to methyl esters was analyzed for water, and it was 0.3 wt%. Apparently, the enzyme has to be further dried to reach its maximal activity.

Effect of substrate flow rate. For these runs, glycerol flow was maintained at 50% of the flow of the soybean oil, which represents a 7-fold molar excess of glycerol. Higher ratios did not increase the monoglyceride yield substantially. Increased flow resulted in a decreased percentage of conversion of the soybean oil, as may be expected because the amount of triglyceride exceeds the catalytic activity of the lipase (Fig. 2A). The effect of higher temperatures is noted from these reactions as well. At 60°C and a flow of 50 μ L/min, enzyme activity is 5.4 μ mol/min/g Novozym 435, whereas at 70°C, activity is 7.1 μ mol/min/g Novozym 435, which is about 30% greater. However, soybean oil solubility is greater at 60°C (0.55 wt%) than at 70°C (0.35 wt%), which

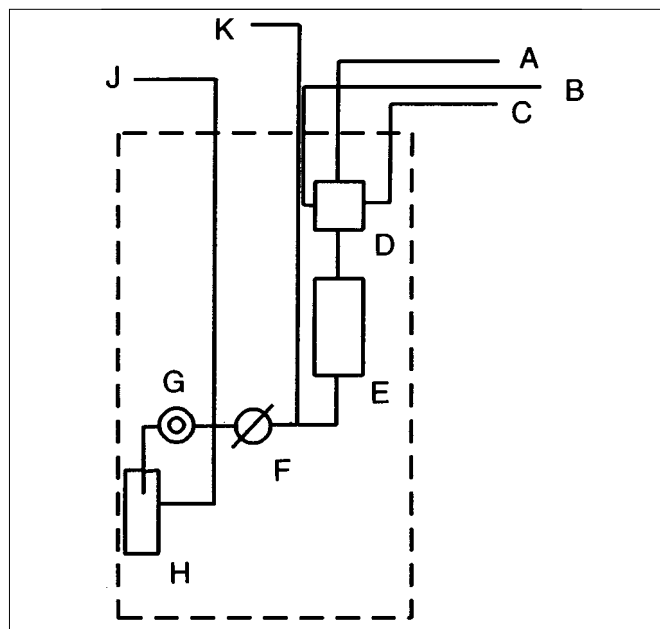

FIG. 1. Schematic of the system used for the reactions in flowing supercritical carbon dioxide. (A) carbon dioxide inlet; (B) alcohol inlet; (C) soybean oil inlet; (D) 4-way tee; (E) reaction cell containing lipase; (F) valve; (G) micrometering valve; (H) receiver; (J) gas vent to dry test meter; (K) pressure gauge. Dashed line represents the thermally controlled region.

TABLE 1
Effect of Water Content of Glycerol (weight%) on Product Distribution^a

	0.7% H ₂ O ^b	4.2% H ₂ O ^b
Free fatty acids	n.d. ^c	1
Monoglycerides	84.0	67.0
Diglycerides	15.4	28.9
Triglycerides	0.6	3.1

^aConditions: Corn oil and glycerol flows 10 μ L/min, 70°C, 27.6 MPa.

^bProduct distributions in weight%.

^cn.d., none detected.

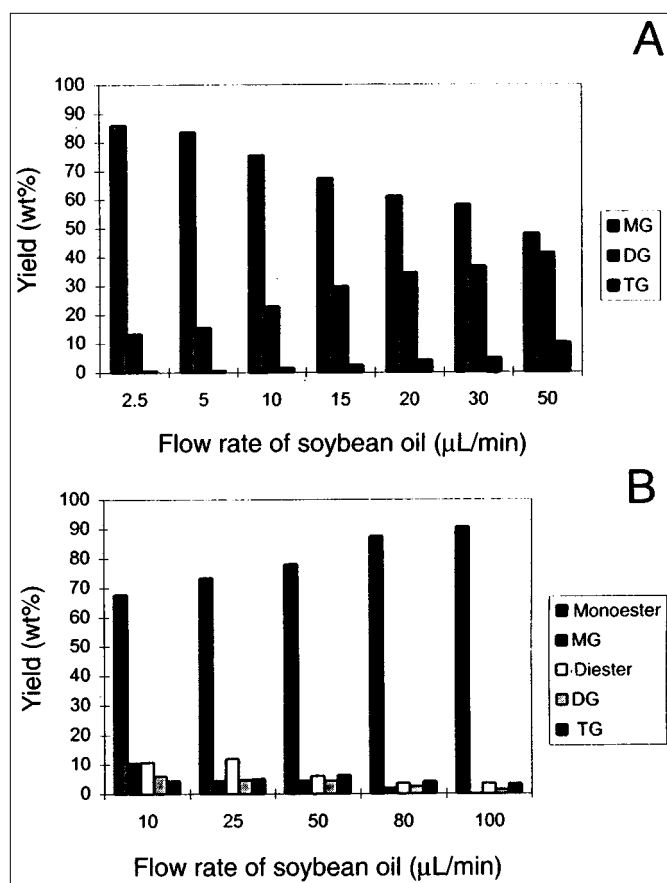

FIG. 2. The effect of flow rate on the reaction of soybean oil with (A) glycerol, and (B) 1,2-propanediol. Abbreviations: MG, monoglyceride; DG, diglyceride; TG, triglyceride. Mono- and diester refer to the esters of 1,2-propanediol.

suggests that the reaction takes place in a heterogeneous phase because at an oil flow of 50 $\mu\text{L}/\text{min}$, the supercritical fluid would be unable to solubilize all of this oil.

The reaction rates of the transesterification of soybean oil with glycerol, 1,2-propanediol, ethylene glycol, or methanol in supercritical carbon dioxide are difficult to compare but appear to be determined by the solubility of the alcohol in supercritical carbon dioxide (19). This is despite the fact that complete solubilization is not necessary for transesterification. As mentioned above, the percentage of soybean oil that reacts with glycerol decreases as oil flow increases. However, examination of the effect of flow on conversion of 1,2-propanediol shows that conversion increases with increased soybean oil flow and, in fact, the conversion rate increases even at soybean oil flow rates that greatly exceed soybean oil solubility (Fig. 2b). At substrate flow rates of 100 $\mu\text{L}/\text{min}$, both the soybean oil and the 1,2-propanediol would precipitate out of the supercritical carbon dioxide. This suggests that the reaction occurs in a multiphase mixture. Indeed, the lipase-catalyzed reaction between 1,2-propanediol and soybean oil occurs in the absence of solvent. Similar results were obtained with ethylene glycol, but this substrate denatured or greatly reduced the activity of the lipase during this study, which prevented acquisition of good data. We have previ-

TABLE 2
Activity of Novozym 435 Toward Various Alcohols

Alcohol	Solubility ^a	Relative activity ^b
Methanol	Miscible	100
1,2-Propanediol	66 mM	90.6
Ethylene glycol	32 mM	53.4
Glycerol	5.4 mM	2.2

^aBased on data in Reference 19.

^bRelative reactivity was calculated from reactions that resulted in optimal conversion of triglyceride for each alcohol.

TABLE 3
Fatty Acid Profiles of the Starting Soybean Oil and the Purified Monoglycerides

Fatty acid	Soybean oil	Monoglycerides
16:0	10.8	10.9
18:0	4.2	4.2
18:1	22.7	23.0
18:2	53.2	52.9
18:3	6.4	6.3

ously shown that Novozym 435 has broad activity in the methanolysis of seed oils. However, as shown in Table 2, the reaction rates for transesterification with polyols vary considerably and parallel the solubility of each substrate in liquid CO₂. Generally, Novozym 435 proved to be stable under the above reaction conditions. All of the glycerolyses were performed with a 10-g sample that transesterified about 100 mL of soybean oil.

Fatty acid profile of the monoglyceride product. The product monoglycerides were purified by a solid-phase extraction method (20). The fatty acid profiles were determined by conversion of the monoglycerides and starting soybean oil to fatty acid methyl esters by using Novozym 435 and methanol. The profiles of the two materials are the same (Table 3), indicating that formation of the monoglyceride is random. This is contrary to a previous report concerning glycerolysis with lipase (21,22), but it agrees with our results on the nonselective methanolysis of seed oils with Novozym 435.

In conclusion, the described synthetic method offers considerable advantage in regulating the solubilization of reactants and products by controlling the density of CO₂. Flow rate of the substrate (soybean oil) has a pronounced effect on the composition of the resultant product mixture and, when controlled properly, it can result in over 90% yield of monoglycerides or monoester when using 1,2-propanediol.

REFERENCES

1. Sonntag, N.O.V., Glycerolysis of Fats and Methyl Esters—Status, Review, and Critique, *J. Am. Oil Chem. Soc.* 59:795A–802A (1982).
2. Yamane, T., M.M. Hoq, S. Itoh, and S. Shimizu, Glycerolysis of Fat by Lipase, *J. Jpn. Oil Chem. Soc.* 35:625–631 (1986).
3. Yamane, T., M.M. Hoq, S. Itoh, and S. Shimizu, Continuous Glycerolysis of Fat by Lipase in Microporous Hydrophobic Membrane Bioreactor, *Ibid.* 35:632–636 (1986).
4. Ferreira-Dias, S., and M.M.R. da Fonseca, Production of Monoglycerides by Glycerolysis of Olive Oil with Immobilized Lipases: Effect of the Water Activity, *Bioprocess Eng.* 12:327–337 (1995).

5. Stevenson, D.E., R.A. Stanley, and R.H. Furneaux, Glycerolysis of Tallow with Immobilized Lipase, *Biotechnol. Lett.* 15:1043–1048 (1993).
6. McNeill, G., S. Shimizu, and T. Yamane, Solid Phase Enzymatic Glycerolysis of Beef Tallow in a High Yield of Monoglyceride, *J. Am. Oil Chem. Soc.* 67:779–783 (1990).
7. McNeill, G., S. Shimizu, and T. Yamane, High-Yield Enzymatic Glycerolysis of Fats and Oils, *Ibid.* 68:1–5 (1991).
8. McNeill, G., and T. Yamane, Further Improvements in the Yield of Monoglycerides During Enzymatic Glycerolysis of Fats and Oils, *Ibid.* 68:6–10 (1991).
9. Akoh, C.C., C. Cooper, and C.V. Nwoso, Lipase G-Catalyzed Synthesis of Monoglycerides in Organic Solvent and Analysis by HPLC, *Ibid.* 69:257–260 (1992).
10. Holmberg, K., and E. Osterberg, Enzymatic Preparation of Monoglycerides in Microemulsion, *Ibid.* 65:1544–1548 (1988).
11. Holmberg, K., B. Lassen, and M.-B. Stark, Enzymatic Glycerolysis of a Triglyceride in Aqueous and Nonaqueous Microemulsions, *Ibid.* 66:1796–1800 (1989).
12. Berger, M., and M.P. Schneider, Enzymatic Esterification of Glycerol II. Lipase-Catalyzed Synthesis of Regioisomerically Pure 1(3)-rac-Monoacylglycerols, *Ibid.* 69:961–965 (1992).
13. Nakamura, K., Biochemical Reactions in Supercritical Fluids, *Trends Biotech.* 8:288–292 (1990).
14. Aaltonen, O., and R. Markku, Biocatalysis in Supercritical CO₂, *Chemtech.* 21:240–248 (1991).
15. Clifford, A.A., Reactions in Supercritical Fluids, in *Supercritical Fluids. Fundamentals for Application*, edited by E. Kiran, and J.M.H. Levelt Sengers, Kluwer Academic Publishers, Dordrecht, 1994, pp. 449–479.
16. Castillo, E., A. Marty, D. Combes, and J.S. Conderet, Polar Substrates for Enzymatic Reactions in Supercritical Fluids: How to Overcome the Solubility Limitation, *Biotechnol. Lett.* 16:169–174 (1994).
17. Jackson, M.A., and J.W. King, Methanolysis of Seed Oils in Flowing Supercritical Carbon Dioxide, *J. Am. Oil Chem. Soc.* 74:353–356 (1996).
18. Neff, W.E., E. Selke, T.L. Mounts, W. Rinsch, E.N. Frankel, and M.A.M. Zeitoun, Effect of Triacylglycerol Composition and Structures on Oxidative Stability of Oils from Selected Soybean Germplasm, *Ibid.* 69:111–118 (1992).
19. Francis, A.W., Ternary Systems of Liquid Carbon Dioxide, *J. Phys. Chem.* 58:1099–1114 (1954).
20. Neff, W.E., M.A.M. Zeitoun, and D. Weisleder, Resolution of Lipolysis Mixtures from Soybean Oil by a Solid-Phase Extraction Procedure, *J. Chromatogr.* 589:353–357 (1992).
21. McNeill, G.P., D. Borowitz, and R.G. Berger, Selective Distribution of Saturated Fatty Acids into the Monoglyceride Fraction During Enzymatic Glycerolysis, *J. Am. Oil Chem. Soc.* 69:1098–1103 (1992).
22. McNeill, G.P., and R.G. Berger, Enzymatic Glycerolysis of Palm Oil Fractions and a Palm Oil Based Mixture: Relationship Between Fatty Acid Composition and Monoglyceride Yield, *Food Biotechnol.* 7:75–87 (1993).

[Received April 1, 1996; accepted September 23, 1996]